

Mini Blender

MK0057 REV 1

munchkin®

IMPORTANT! KEEP FOR FUTURE REFERENCE

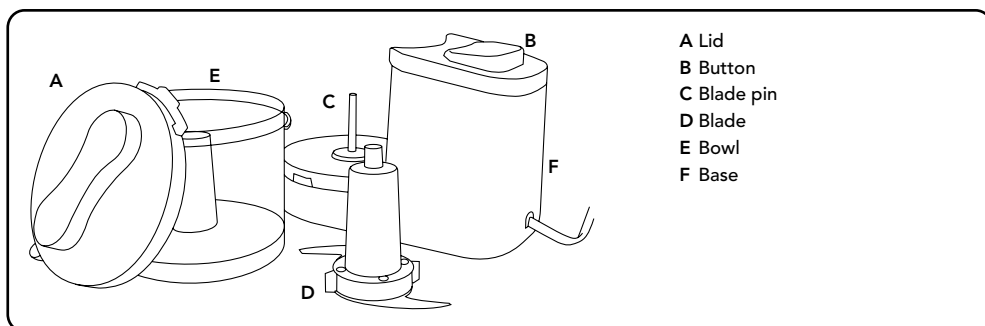

Before You Use Your Mini Blender:

Read all instructions and keep for future reference. Wash the lid, bowl and blade in warm soapy water. Do not immerse the motor unit in water. If the base needs to be cleaned, wipe it down with a damp cloth. Do not use abrasive cleaning implements as this can scratch the plastic of the bowl. Dry all parts thoroughly.

To Use:

1. Ensure the surface you are using is clean, dry and level.
2. Place the bowl onto the base. Align the notches on the base of the bowl with the groove on the base unit. The bowl can be secured or released by following the directions and arrows on the base unit.
3. Place the blade onto the blade pin.
4. Put the ingredients inside the bowl.
5. Place the lid onto the bowl. If the lid is not fitted correctly then the Mini Blender will not operate. When in place the arrows will be aligned and the lid will have clicked into place.
6. Plug the unit into the mains.
7. Press down on the button at the top of the base unit to start blending. When you take the pressure off the button, this will stop blending. It may take a couple of seconds for the blade to stop completely.
8. Important: This Mini Blender is designed for a maximum running time of 40 seconds on followed by a minimum of 40 seconds off. Do not repeat this cycle for more than 3 minutes without a rest time of 3 minutes.
9. When you have blended contents as required, unplug from the mains and wait for the blade to stop completely before removing the lid.
10. Remove the lid and blade (scraping off any food left on the blade into the bowl).
11. Remove the contents of the bowl.

To Clean:

The bowl and lid can be hand washed in warm soapy water, or in the top rack of the dishwasher up to a temperature of 75°C. **DO NOT** place in the lower rack. Wipe the base unit with a damp cloth if required. **DO NOT IMMERSE THE BASE UNIT IN WATER.** Dry all parts thoroughly before use.

Important:

- Read all instructions carefully before using the Mini Blender. Retain instructions for future reference.
- All parts of the unit are **NOT** suitable for steam or microwave sterilisation.
- Do not immerse any electrical parts in water as this could result in electric shock.
- Close supervision is necessary when this appliance is used around children.
- Ensure the unit is unplugged when not in use and before dismantling or assembling the appliance.

- Avoid contact with moving parts.
- Do not operate the appliance if the power cord has been damaged or the appliance has been dropped or damaged in any way. **NO USER SERVICEABLE PARTS.**
- Contact your service agent if the cord is damaged.
- Do not use any attachments or accessories other than those supplied with this product.
- Do not use outdoors.
- Never allow the power cord to hang over the edge of the work surface or table to avoid danger of it being pulled off by a child.
- Keep hands, utensils and other foreign objects out of the chopping bowl when in use as this could lead to injury. Do not use sharp objects or utensils in the chopping bowl as they may scratch or damage the inside of the bowl.
- Do not place on or near a hot gas or electric burner or in a heated oven.
- Do not use this appliance for other than the intended use.
- Do not use the appliance when empty.
- Care is needed when handling cutting blades especially when removing the blade from the bowl, emptying the bowl or during cleaning.
- This appliance is not intended for use by persons (including children) with reduced physical, sensory or mental capabilities, or lack of experience and knowledge, unless they have been given supervision or instruction concerning use of the appliance by a person responsible for their safety. Children should be supervised to ensure they do not play with the appliance.

Advice on Feeding:

The following advice should be used as a guideline only. For detailed feeding advice consult a health professional.

The time needed to blend sufficiently will depend on the food type you are using. Adding a little cool water will aid blending and give a smoother consistency if required.

Cook food for your baby until soft. Puree to a smooth runny consistency in your Mini Blender. Ensure no pips or skin remain and remove fat, skin or gristle from meat before pureeing. If there is any history of allergy or asthma in your family, delay the introduction of foods which may trigger an allergic reaction such as eggs, foods containing wheat or gluten, citrus fruits, dairy products and nuts.

Wait until your baby is at least 6 months before introducing these foods. It is important, however, not to exclude these products after around six months without talking it through with a health professional.

Do not add salt or sugar to your baby's food.

WARNING! IMPORTANT INFORMATION FOR THE BOWL

- The bowl and lid can be hand washed in warm soapy water, or in the top rack of the dishwasher up to a temperature of 75°C. **DO NOT** place in the lower rack.
- The bowl and lid are **NOT** suitable for steam or microwave sterilisation.
- **DO NOT** use the bowl in a microwave to heat food or liquids. Please refer to your instruction booklet for full details.
- Do not blend more than 50g of food at any one time.

munchkin[®]
It's the little things.[®]



MON-FRI, 10AM - 4PM, UK ONLY. CALLS COST 10 PENCE PER MINUTE FROM A BT LANDLINE. CALLS FROM OTHER NETWORKS AND MOBILES MAY COST MORE.

PRODUCT DESIGN IS TM & ©2012 MUNCHKIN, INC. CA 91343. IMPORTED BY LINDAM LTD (THE EUROPEAN DIVISION OF MUNCHKIN INC), UNIT 760, THORP ARCH TRADING ESTATE, WETHERBY, WEST YORKSHIRE, LS23 7FW, ENGLAND. MADE IN CHINA. MUNCHKIN AND IT'S THE LITTLE THINGS ARE TRADEMARKS OF MUNCHKIN, INC.